



**BURR KING MFG. CO., INC**

1220 Tamara Lane

Warsaw, MO 65355

www.burking.com

(660)438-8998 • Fax (660)438-8991



# MODEL 12 INSTRUCTION MANUAL



*Model 29140 Shown with optional pedestal*

**MADE IN U.S.A.**



- \* GRINDERS
- \* BUFFERS
- \* VIBRATORY
- \* DISC GRINDERS

# BURR KING MODEL 12 DISC GRINDER



**BURR KING MFG. CO., INC.**

1220 TAMARA LANE

WARSAW MO 65355

WWW.BURRKING.COM

**(660) 438-8998 ♦ (800) 621-2748**

**FAX (660) 438-8991**

June, 2007

Burr King Manufacturing Company, Inc. warrants the below product to be free in material and workmanship. The period of warranty is 1 year (90 days for vibratory bowls of 20 quart and lesser volume) from the date of purchase. No warranty is provided for products that have been modified, abused, handled carelessly, where repairs have been made or attempted by others, or for freight damage. No warranty is provided for three phase electric motors, controllers, etc. when the motors, controllers are not protected by magnetic starters that were supplied and installed by Burr King Manufacturing Company, Inc. No other warranty, written or verbal is authorized by Burr King Manufacturing Company, Inc.

During the warranty period Burr King Manufacturing Company, Inc (or its authorized suppliers or agents) will replace or repair the below product without charge if the product is found by Burr King Manufacturing Company, Inc. to be defective. To receive warranty services you must contact Burr King Manufacturing Company, Inc. and receive authorization fir warranty service. Unless otherwise authorized by Burr King Manufacturing Company, Inc. Products (see \* below) must be returned to the factory to receive warranty service.

\*Motors, speed controllers, and certain other accessories are warranted by their respective manufactures. To receive warranty service on these items you must contact a brand label service center that supports the product in need of service. Burr King Manufacturing Company; Inc. will assist you in locating a service center.

For the first thirty days after purchase, and when Burr King Manufacturing Company, Inc. authorizes warranty service, we will pay normal and necessary surface freight charges both ways (except for items in \*). After thirty days the customer is responsible for all freight charges. Where possible Burr King Manufacturing Company, Inc. may elect to make on site service and/or repairs necessary to return the product to serviceable condition.

To assure prompt warranty service it is necessary that you complete and return the below warranty information to Burr King Manufacturing Company, Inc. please **FAX** or **MAIL** at your convenience.

Product model: \_\_\_\_\_ Serial number: \_\_\_\_\_  
Date Purchased: \_\_\_\_\_ Purchased from: \_\_\_\_\_  
Address: \_\_\_\_\_ City: \_\_\_\_\_ State/Prov: \_\_\_\_\_ Postal code \_\_\_\_\_

Your company name: \_\_\_\_\_  
Address: \_\_\_\_\_ City: \_\_\_\_\_ State/Prov: \_\_\_\_\_ Postal code \_\_\_\_\_  
Phone: \_\_\_\_\_ Fax: \_\_\_\_\_ Email: \_\_\_\_\_  
Your name: \_\_\_\_\_ Title: \_\_\_\_\_

How did you learn about Burr King products?

Trade show \_\_\_ Web \_\_\_ Industrial Distributor \_\_\_ Advertisement \_\_\_ Other \_\_\_\_\_ Which one: \_\_\_\_\_

What is the intended use of this product? \_\_\_\_\_

Please indicate the general work types performed at your company. check all that apply:

Fabrication \_\_\_ Machining \_\_\_ Casting \_\_\_ Molding \_\_\_ Welding \_\_\_ Finishing \_\_\_ Assembly \_\_\_ Research \_\_\_ Other \_\_\_

Please indicate the primary product focus of your company; check all that apply.

Aircraft/Missile \_\_\_ Automotive \_\_\_ Contract machine \_\_\_ Contract Fabrication \_\_\_ Agricultural \_\_\_ Maintenance \_\_\_ Recreational \_\_\_  
Job shop \_\_\_ Foundry \_\_\_ Construction \_\_\_ Arts \_\_\_ Orthopedic \_\_\_ Dental \_\_\_ Medical \_\_\_ Other \_\_\_\_\_

Please tell us what we can do to improve our products:

\_\_\_\_\_  
\_\_\_\_\_

May we contact you? Yes \_\_\_ No \_\_\_

**Thank you for purchasing Burr King products!**

**REGISTER ONLINE @  
WWW.BURRKING.COM**



**BURR KING MFG. CO., INC.**

1220 TAMARA LANE

WARSAW MO 65355

WWW.BURRKING.COM

**(660) 438-8998 s (800) 621-2748**

**FAX (660) 438-8991**

June 21, 2007

**LETTER OF AUTHENTICITY**

This letter is to certify that all Burr King Belt grinders, Disc grinders, Polishing machines Vibra King Chambers and Bowls are manufactured and assembled in the United States of America.

(Tariff number 847990 criterion A)

A handwritten signature in black ink, appearing to read "Don Mac Carthy".

Don Mac Carthy  
President

See our catalog at [www.burrking.com](http://www.burrking.com)

contact us at [info@burrking.com](mailto:info@burrking.com)



**BURR KING MFG. CO., INC.**  
1220 TAMARA LANE  
WARSAW MO 65355  
WWW.BURRKING.CO  
**(660) 438-8998 s (800) 621-2748**  
**FAX (660) 438-8991**

February 2005

## **OPERATOR, and OPERATING AREA SAFETY**

**Subject equipment includes Grinders, buffers, polishers, and other rotating equipment. Serious injury or death may occur if minimum safety precautions are not understood, and obeyed by operators and those other persons who may be in the immediate vicinity of the subject equipment. Persons who operate, or are in the immediate vicinity of the subject equipment must be properly trained in, and use, minimum safety precautions and procedures for such machinery.**

### **Minimum safety requirements to operate, or work in the immediate vicinity subject equipment:**

1. Read and understand all operating instructions, manuals, labels, and other information provided with the equipment.
2. Install the equipment according to manufacturer's instructions.
3. Securely bolt the equipment to a rigid, structurally sound mounting surface.
4. Use and wear proper eye and face protection.
5. Use and wear proper protection for the body, hands, fingers, feet, and legs.
6. Review and understand all machine guards, adjustments, and points of exposure to potential injury.
7. Do not remove, tamper with, or otherwise alter, equipment guards, and other safety features.
8. Insure the machine is adjusted, and remains adjusted according to manufacture's requirements.
9. Maintain the equipment in good operating condition.
10. Have another person who is knowledgeable in proper and safe operation of the subject equipment demonstrate proper and safe operation to all operators, and to those persons who might be in the immediate vicinity of the subject equipment.
11. Use work piece holding devices when ever possible that diminish the possibility that persons will come in contact with moving machine pieces, or spark/debris output from the machine.
12. Use spark and debris arresting apparatus. Such apparatus should be connected to the machine so as to contain dust and debris that is generated, and to suppress sparks thereby limiting human inhalation risk, and the risk of fire or explosion.
13. Use appropriate inhalation apparatus to protect person from ingestion and/or inhalation of sparks, debris, smoke, particulates, etc.
14. Avoid mixing different metals, alloys, and materials. To mix such materials might create a fire or explosion hazard.
15. Protect persons from work pieces, particulates, etc. that could be forcibly ejected from the machine. For example, a buffing wheel or grinding belt can "grab" a work piece while the work piece is being buffed, polished, ground, or otherwise conditioned, resulting in forcible ejection toward the operator or those in the vicinity of the machine. The use of leather aprons, gloves, and eye shields are examples of protective gear that may be effective. In general do not grind, buff, or otherwise engage the traveling belt, wheel, or disc surface with the work piece pointing into the direction from which the belt, wheel, or disc is traveling. However, if you choose to do so be aware the work piece may lodge in the traveling belt, wheel, or disc and be forcibly, and dangerously ejected.
16. Do not operate this machine if the gap (nip point) between a moving belt, wheel or disc and the work support surface exceeds 1/8 inch.
17. Do not operate this machine if the gap between the moving abrasive belt, disc or wheel and the adjacent face

page 1 continued on next page

Continued from page 1

of the work rest (or table) will permit passage of the work piece through the gap (nip point). Note, however, that certain alloys such as titanium may create conditions where grinding debris can accumulate in a tight gap creating a potential fire hazard. **When in doubt consult with your safety officer.** Failure to observe this warning may result in the work piece or other item being caught in this gap, and/or being forcibly ejected. Failure to heed this warning may cause serious bodily harm to the operator and/or bystanders. **NEVER USE THIS EQUIPMENT IF YOU ARE NOT PROPERLY TRAINED IN ITS OPERATION and/or SAFE USE! IF IN DOUBT STOP and ASK FOR GUIDANCE!**

18. Never position the work rest table at an acute angle between the top of the work rest table and the moving belt or wheel. Doing so will create “nip point” that can cause serious injury should an operator body part become entangled (pulled into) the nip point created by this acute angle.

19. Do not operate the equipment, or allow others to operate the equipment without proper training in these and other rotating machinery safety requirements.

20. Do not perform maintenance on the equipment unless you are fully qualified to do so, and understand all necessary safety and operating requirements.

21. Do not leave the machine unattended while it is running.

22. Correct equipment or safety problems immediately. Do not operate the equipment when it requires maintenance, or correction.

23. Install and use high quality abrasive belts, wheels, discs, media, etc., as appropriate to your machine. Understand and follow the operating requirements provided by the manufacturer of these materials.

### **Rotational Speed Warning, Contact Wheels**

Scope: Contact wheels manufactured by Burr King Manufacturing Company, Inc., which have rubber or urethane tires. Examples include but are not limited to stock codes 202, 302, 402, 502, 702, 802, 902, 1002, 1202 and variants. Variants have stock codes that begin with the base number; i.e. 802-S-55 is an 802 variant.

Users are warned not to exceed the below listed revolutions per minute (RPM) on the subject wheels. Failure to heed this warning may lead to tire de-bonding, fragmentation, or other mechanical failure. Such failures may cause serious personal injury to operators or bystanders, and/or cause property damage. All Burr King products are warranted for various time periods to be free of material and/or workmanship defects. Burr King Manufacturing Companies standard warranty policy is summarized as follows for contact wheels. 1 year from date of purchase if mounted on a Burr King machine purchased on the same date or 90 days if purchased as a spare or replacement part. Our warranty does not apply to wheels that are mounted on products not manufactured by Burr King Manufacturing Company, Inc. Users who mount Burr King manufactured contact wheels on product not manufactured by Burr King Manufacturing Company, Inc. do so at their own risk and assume all liability for having so mounted the contact wheel(s).

Remember good safety practice demands guarding to protect operators and bystanders from wheel failure and/or debris. Never use the subject contact wheels without proper guarding that meets commonly accepted safe practice. See OSHA, U/L, CSA, CE, ISO and other respected safety standards.

<u>Stock code</u>	<u>Maximum Safe RPM</u>
202, 302	10000
402, 502, 702 802	4400
902, 1002	2200
1202	1600

Page 2, continued on page 3

Continued from page 2

**Occupational Noise Exposure**

Burr King products produce levels of noise consistent with their intended purposes. The level and spectral content of noise produced is dependent on the product type, the degree that the product is maintained in proper operating condition, the abrasive/media and accessories used, the specific application, and the surrounding environment. Noise levels produced by various Burr King grinders and polishers, as measured at the Burr King factory, range from 80 to 93 decibels. Product operators and persons in the immediate product vicinity should be protected from excessive noise does levels as prescribed in OSHA regulation 29, piece 1910.95 titled "Occupational Noise Exposure".

**ROTATING EQUIPMENT CAN BE DANGEROUS TO OPERATORS AND THOSE WHO MAY BE IN ITS IMMEDIATE OPERATING VICINITY. IT IS THE ABSOLUTE AND DIRECT RESPONSIBILITY OF PURCHASERS, MANAGERS, AND OPERATORS OF THIS EQUIPMENT TO UNDERSTAND AND OBEY THE FOREGOING MINIMUM OPERATING SAFETY REQUIREMENTS. IF YOU HAVE QUESTIONS OR SAFETY CONCERNS REGARDING OPERATING THE SUBJECT EQUIPMENT PLEASE CALL YOUR AUTHORIZED BURR KING DISTRIBUTOR, OR BURR KING MANUFACTURING AT 1-800-621-2748. YOUR SAFETY IS OUR FOREMOST CONCERN!**

**Burr King Manufacturing disclaims any and all responsibility for injuries, damage, loss of income, or other adverse consequence as might be incurred by purchasers, managers, and operators of this equipment.**

**Page 3 is last page**



## BURR KING MFG. CO., INC.

1220 TAMARA LANE

WARSAW MO 65355

WWW.BURRKING.COM

(660) 438-8998 ♦ (800) 621-2748

FAX (660) 438-8991

August 17, 2007

### **Installation/Operating instructions for the model 12 disc grinder**

The model 12 disc grinder is a medium duty disc grinder intended for de-burring, shaping, beveling, metals, plastics, woods, and other materials using a 12 inch PSA abrasive disc that rotates at speeds up to 1750 RPM. It has a work table that can be tilted to 45 degrees and maintained at a selected angle. The model 12 is available in fixed and variable speed configurations with motors of 1, 1.5, and 2 horsepower. The model 12 must be securely bolted to a substantial work table or be mounted on the optional pedestal that must be securely bolted to the floor.

Prior to operating the model 12 please take time to do the following:

1. Insure that you have received all of the items that you ordered. Compare the packing slip with your purchase order, and of course with the physical items received.
2. Verify that there is no obvious shipping damage. If shipping damage is discovered notify the freight carrier of your intention to file a freight damage claim. They will assist you.
3. Verify that the AC power that is identified on the machine as received matches the AC power that you intend to operate the machine with. Do not modify the machine's wiring without first contacting your distributor and/or Burr King Manufacturing.
4. Do not modify or defeat any AC wiring safety feature.
5. Verify that you have received a warranty card, parts lists, catalog, and Operator, and Operating Area Safety Instructions.
6. Complete the warranty card and return it to Burr King Manufacturing.
7. Verify that all guards are in place and functional.
8. Insure that the grinder is located in an area that provides clear access to the machine such that operators have safe and unobstructed access to the machine. The work place should be free from floor obstructions, trip points, and other faults that may reduce operator safety.
9. Burr King recommends that all three-phase installations include a magnetic starter. Magnetic starters protect motors from "single phasing", overheating, etc. thereby reducing the risk of damage to the equipment and/or fire hazard to your facility. Note that models with variable speed control supplied by Burr King include the foregoing safety features without the addition of a magnetic starter.
10. Insure that the model 12 AC power source is properly sized, and properly fused. Refer your local codes and/or to national electric codes for guidance.

Functional operating instructions for the model 12 belt grinder

The model 12 was fully tested and verified to comply with requirements prior to shipping from the factory. No adjustments should be necessary. You should perform the following steps:

1. Securely bolt the machine to the floor. Note that the pedestal base has four holes that are sufficient for ½ inch anchor bolts. Do not use anchor bolts that are less than 3/8 inch in diameter and/or that do not provide for at least 2 ½ inches of depth grip in secure concrete.
2. Verify that the disc spins freely.
3. Verify that the gap (nip point) between the PSA abrasive disc and the table edge next to the front of the disc is less than 1/8 inch. This gap is set at the factory to comply with this requirement. The gap should not change unless table erosion occurs, maintenance to the machine is attempted, or damage has occurred.

4. To install or remove an abrasive disc remove the 3/8 bolts that are located just under the table and on either side of the table. Tilt the table away from the disc. Install the PSA disc taking care to position it concentric to the aluminum backing disc.

Note: PSA abrasive discs can leave a residue on the aluminum backing disc. Normally this can be cleaned with isopropyl alcohol and a soft rag.

5. As before assure that the disc spins freely.
6. Reposition the table, reinstall the 3/8 bolts.

#### Grinding modes

1. The direction of disc rotation determines the point of grinding.

**Never grind on the side of the disc where the movement of the abrasive disc is upward from the table. Doing so may create an operator hazard from debris, and or ejected work pieces.**

2. Supported work: Always use work piece holding devices to minimize the risk of operator contact with the rotating abrasive disc.
3. For controlled angle grinding tilt the table down to any angle from 0 to 45 degrees. Read the angle on the indicator found on the right hand table support. Note: Use of a precision protractor is recommended where angles of plus/minus 2 degrees are required.
4. Disc rotation can be selected using the provided control if so equipped. This control may be a simple selector switch, or an electric control module depending on how your model 12 is equipped.

**Note: Never grind with the table tilted in an acute angle (up) in respect to the disc while holding the work piece by hand. The disc may seize the part stall the machine, and or injure the operator.**

#### Maintenance for the model 12

**ALWAYS DISCONNECT THE MACHINE FROM ITS AC POWER SOURCE PRIOR TO CHANGING THE PSA DISC OR PERFORMING MACHINE MAINTENANCE.**

1. Vacuum or otherwise remove dust and debris build-up from the machine.
2. Keep the dust channel under the disc and any connected dust conduits free from dust build up.
3. Use spark arrest devices to minimize the risk of fire or explosion.

## **Remember for optimum operator safety and the continued effectiveness of your model 12:**

**Read and understand these instructions and the included “Operator and Operating Area Safety” instructions.**

**Never position work pieces at an acute up angle with disc with the table at any angle. Doing so may lead to serious operator or bystander injury.**

**Never grind material that is less than ¼ inch thick in its smallest dimension without the use of work piece holding devices to protect the operator and/or bystanders. Failure to use a holding device may lead to serious operator or bystander injury.**

**Beware that thin (less than ¼ inch) material can lodge in the gap between the table and the disc creating a potential for serious injury, and/or property damage.**

**Do not operate the model 12 until you are fully trained to do so safely.**

**Do not defeat the safety guards and other safety provisions of the model 12.**

**Do not operate the model 12 with safety guards removed, or counter to these instructions.**

See our catalog at [www.burrrking.com](http://www.burrrking.com)

Contact us at [info@burrrking.com](mailto:info@burrrking.com)

DOC 12DISCOP-99 12/05



**Do not reach inside the safety guards while the machine is running.**

**Do not use fluids in your grinding process unless your model 12 is designed for liquid operation (NEMA 4, 4X). To do so may create an electrical safety hazard. Only specially ordered model 12 grinders are “liquid safe”.**

**Do not use your model 12 to grind/polish explosive materials unless it is equipped with explosion proof electrical devices and motor.**

**Do not mix alloys in your grinding. To do so may create an explosion/fire hazard.**

**Do not modify the model 12 other than securing holding devices to the work table.**

**Do use eye, hand, face, arm, leg, feet and body protection that is adequate to protect against flying debris, forcibly ejected work pieces, etc. Note: Consult with your safety officer in regard to your facilities policy regarding attire such as gloves when using rotating equipment.**

**Do train operators and others in safe operating practices.**

**Post these or equivalent instructions such that they are available for ready operator reference.**

Burr King Manufacturing can help you with problem solutions, and/or answers to your questions. Please call your Burr King distributor first. If you can not reach satisfactory conclusion please call the Burr King factory, telephone 1-660-438-8998.

# M12 DISC GRINDER

## SCHEMATIC

BURR KING

1220 TAMARA LANE  
WARSAW, MO. 65355

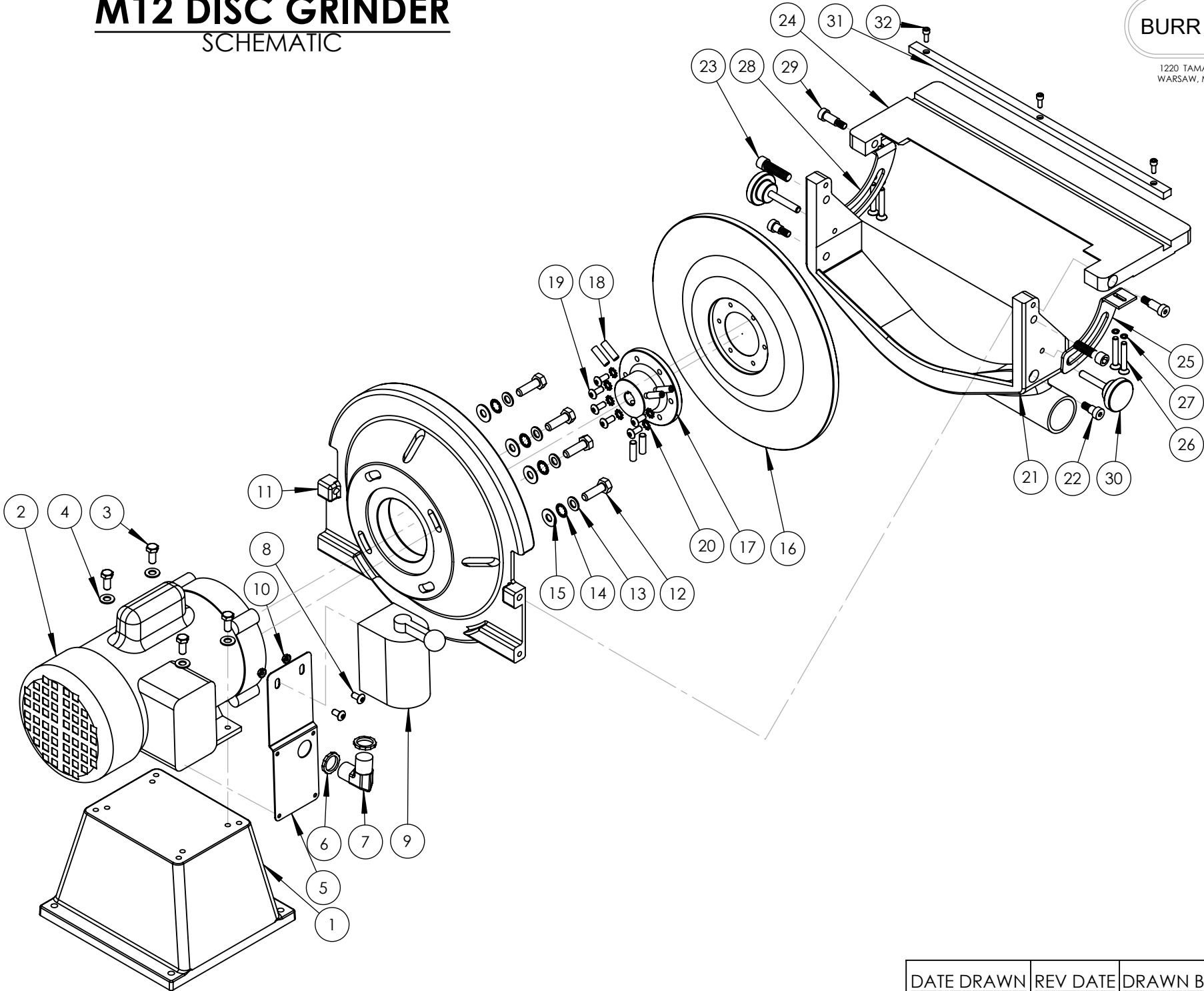

DATE DRAWN	REV DATE	DRAWN BY	SHEET
8/1/2009	9/9/2009	CMW	1 OF 2

## 12" DISC GRINDER

**BURR KING**

1220 TAMARA LANE  
WARSAW, MO. 65355

ITEM NO.	PART NUMBER	DESCRIPTION	QTY.
1	941	BASE	1
2	MOTOR	CALL FRACTORY FOR MOTOR	1
3	2	BOLT, 5/16-18 x 1/2 HH GRD5	4
4	4	WASHER, 5/16 SAE ZINC PLTD	4
5	99-0046	PLATE, MOTOR SWITCH	1
6	4-0017	NUT, 1/2" LOCK	4
7	99-0052	FITTING, ELBOW 1/2" MALE	1
8	2-0014	SCREW, 1/4-20 x 1/2 BH	2
9	9942	SWITCH, 115V/ 1 HP	1
10	4-0013	NUT, KEP, 1/4-20	2
11	8705	ADAPTER, BELL	1
12	1-0003	BOLT, 3/8-16 x 1 1/4 HEX HEAD	4
13	17	WASHER, 960-616, AN	4
14	5-0014	WASHER, LOCK 3/8, INTERNAL STAR	4
15	42	WASHER, SAE, 3/8	4
16	8700	DISC, 12"	1
17	8702-1 8702	HUB, 5/8" HUB, 7/8"	1
18	421A	SCREW, 5/16-18 x 1 SOCKET SET	6
19	2-0046	SCREW, 1/4-28x5/8 BH	6
20	5-0008	WASHER, 1/4, LOCK, EXTERNAL	6
21	8703	GUARD, LOWER	1
22	1-0040	BOLT, SHOULDER, 5/16-18 x 3/8 x 3/8	2
23	2-0010	BOLT, 3/8-16 x 1 1/2 SHCS	2
24	8704	TABLE	1
25	8707	SUPPORT, TABLE, INDEX, RH	1
26	9	SCREW 10-24 x 1/2 BH	4
27	15	WASHER, #10 LOCK	4
28	8706	SUPPORT, TABLE, INDEX, LEFT	1
29	1-0041	BOLT, SHOULDER, 5/16-18 x 3/8 x 3/4	2
30	711-1	KNOB ASSY, TRACKING	2
31	8708	FILLER, TABLE	1
32	2-0052	SCREW, 10-24 X 1/2 ALLEN CAP	3

TITLE	DATE DRAWN	REV DATE	DRAWN BY	SHEET
M12 DISC GRINDER	8/1/2009	9/9/2009	CMW	2 OF 2

# M12 DISC GRINDER

FOOT PRINT

BURR KING

1220 TAMARA LANE  
WARSAW, MO. 65355

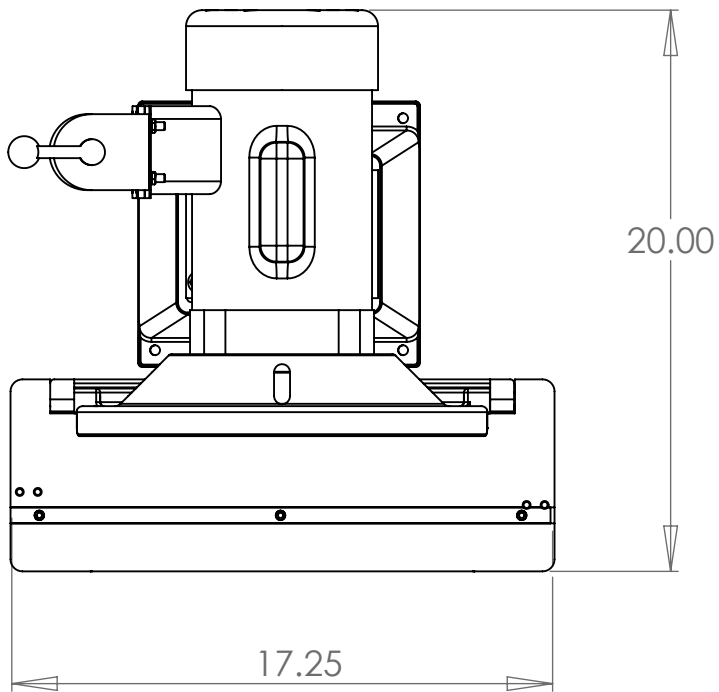

**TOP VIEW**

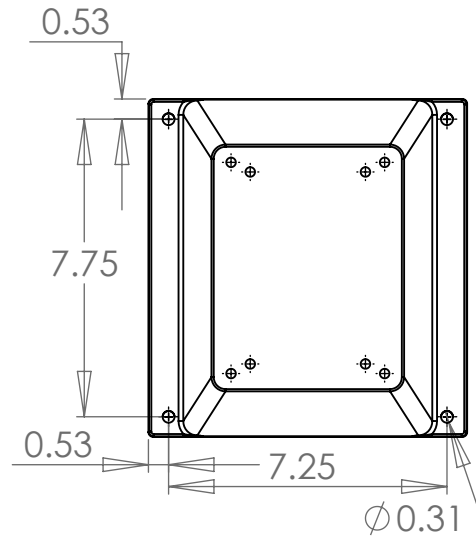

**MOUNTING PATTERN**

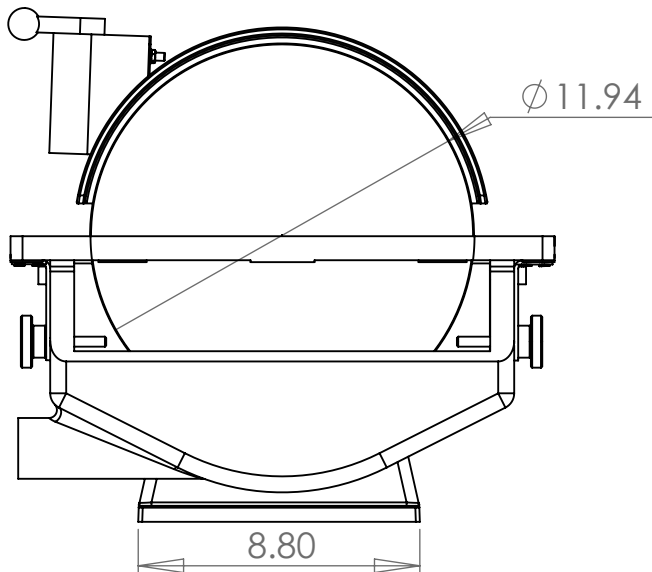

**FRONT VIEW**

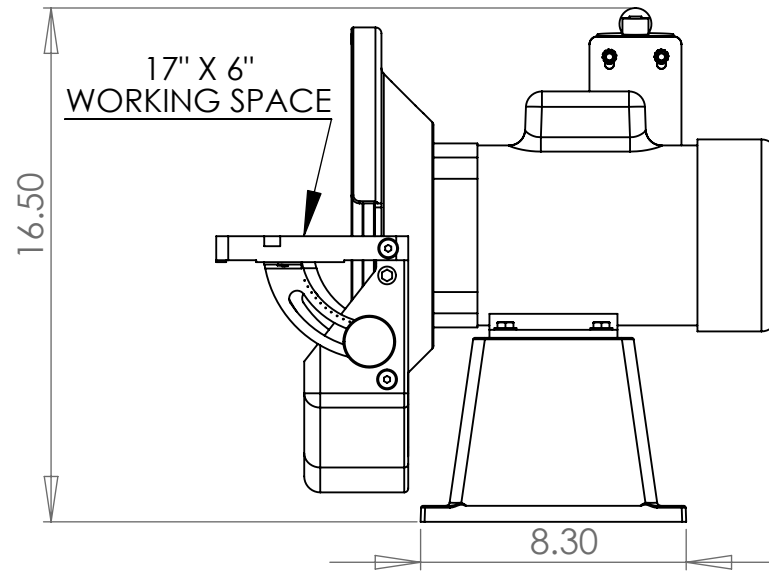

**RIGHT SIDE VIEW**