

M1051 EXPLODED VIEW

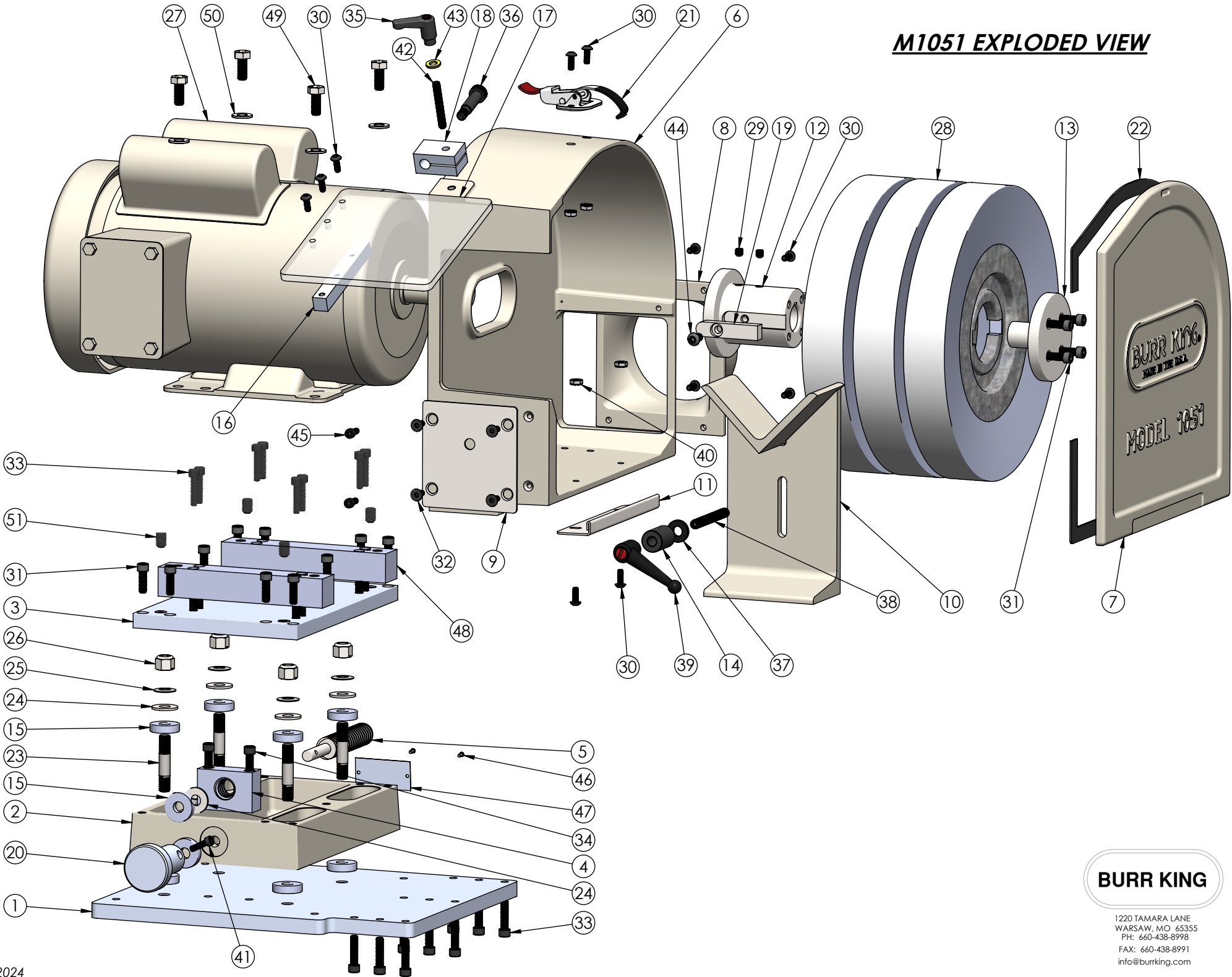

1220 TAMARA LANE
 WARSAW, MO 65355
 PH: 660-438-8998
 FAX: 660-438-8991
 info@burrking.com

M1051 PARTS LIST

ITEM NO.	PART NUMBER	DESCRIPTION	QTY.
1	105101	BASE-MAIN	1
2	105102	SLIDE-MOTOR BASE	1
3	105103	BASE-MOTOR	1
4	105104	NUT-ADJUSTER	1
5	105105	SCREW-ADJUSTER	1
6	105106	GUARD,WHEEL	1
7	105107	DOOR-WHEEL GUARD	1
8	105108	CHUTE-DUST 4"	1
9	105109	PLATE-WEAR	1
10	105110	WORKREST-REVERSIBLE	1
11	105111	RETAINER-DOOR	1
12	105112-1	ARBOR-WHEEL 7/8 x 2	1
13	105113-1	CAP-ARBOR 7/8	1
14	105114	SPACER-CLAMP	1
15	105115	SLIDE-N-GLIDE	10
16	105117	MOUNT-SHIELD	1
17	105118	SHIELD-SCATTER	1
18	105119	CLAMP/SWIVEL	1
19	105120	KEY-ARBOR	2
20	105121	KNOB-ADJUSTING	1
21	105122	LATCH-DOOR	1
22	NEOP-PAD-1	SEAL-DOOR	1
23	920K	STUD 3/8"x 1.93", DOUBLE	4
24	5-0023	WASHER-FLAT 5/16 USS	5
25	5020-4	SPRING-BELLEVILLE	4
26	22	NUT-NYLOCK 3/8-24	4

ITEM NO.	PART NUMBER	DESCRIPTION	QTY.
27	145T	MOTOR-CALL FACTORY	1
28	WW-31	WHEEL-WIRE 10 x 1	3
29	7-0068	SET SCREW 1/4-28 x 1/4 FP	6
30	9	BHSHCS 10-24 X 1/2	11
31	209	SHCS 1/4-20 X 3/4	14
32	7-0055	10-24 x 1/2 FHSHCS	4
33	30	SHCS 1/4-20 X 1	17
34	31	SHCS 1/4-20 X 1 1/4	2
35	7-0052	LOCK HANDLE-SMALL	1
36	2-0063	3/8 x 1 SHOULDER SCREW	1
37	7-0045	WASHER-HARD 5/16	1
38	921A-1	SET SCREW 5/16-18x2 3/4 CP	1
39	1203	HANDLE,LEVER 5/16-18	1
40	14	NUT, 10-24 KEP	4
41	13	SHCS 10-24 x 3/4	1
42	7-0069	SET SCREW 1/4-20 x 1 3/4 CP	1
43	5	WASHER 1/4 AN960-416	1
44	2-0028	BHSHCS 1/4-28 x 1/2	2
45	2-0052	10-24 x 1/2 SHCS	2
46	28	SCREW, DRIVE, #2 x 1/4	2
47	LABEL 20	BK S/N PLATE	1
48	105123	ADAPTER-MOTOR SF	2
49	37	CAPSCREW 5/16-18 X 3/4	4
50	4	WASHER 5/16 SAE	4
51	7-0072	SET SCREW 3/8-24 x 3/8 CP	4

** 105124 - 1/2" WHEEL SPACER FOR RUNNING LESS THAN 3" **