



BURR KING MFG. CO., INC.

1220 TAMARA LANE

WARSAW MO 65355

WWW.BURRKING.COM

(660) 438-8998 ♦ (800) 621-2748

FAX (660) 438-8991

January, 05

Dear Customer,

Thank you for purchasing the Burr King model 960-401/960-251 wet grinder. We are confident that it will add value to your projects. Please note that the belt that is now on the machine (it is orange-brown in color) is **NOT** a wet capable belt.

Do not use water on the belt we have provided to you with the machine, as it may fail to provide the service you expect, and or physically fail.

Abrasive belts will vary in length, straightness, flexibility, etc. Because of this you need to be particularly aware when you first install a new belt. If you do the following you will attain greater satisfaction with each new belt:

Assure the grinder is securely bolted to a stable work surface.

Disconnect the AC electric power from your grinder.

- Push up on the rear wheel-tensioning handle and while holding the handle up push the red button in the handle center to release the pawl from the ratchet.
- Lower to its lower most position the tensioning handle to remove tension from the old belt.
- Open the safety guard door
- Remove the old belt
- Install the new belt taking care that it is not bent, wrinkled, or otherwise deformed. The belt should now be around the upper and lower wheel and be slack.
- Without pushing the red button push up on the tensioning handle. You will hear the pawl click as the handle is moved upward. Push the handle back until you have heard 6 to 7 clicks.
- Manually rotate the belt on the wheels several rotations and see that the belt stays centered on the wheels within about ¼ inch or less. If it does not, loose the locking handle on the tracking knob located on the upper left of the machine. CW rotation of the tracking knob will move the belt to the left, CCW to the right. Turn the knob ¼ turn in the required direction while manually rotating the belt to observe the tracking effect. Adjust tracking as necessary.
- Close the machine guard door
- Connect the electric source.
- Momentarily engage the motor. The belt should run within ¼ inch of the wheel centers. If the belt tracks within ¼ inch turn on the machine and slowly turn the tracking knob in the required direction to fully align the belt.
- Secure the tracking knob locking handle

This page intentionally
left blank



BURR KING MFG. CO., INC

1220 Tamara Lane

Warsaw, MO 65355

www.burking.com

(660)438-8998 • 800-621-2748

Fax (660)438-8991

MODEL 960-401 INSTRUCTION MANUAL



MADE IN U.S.A.



BURR KING.

- GRINDERS
- BUFFERS
- VIBRATORY
- DISC GRINDERS

*Model 30000 shown
with optional pedestal*

BURR KING MODEL 960-401 WET GRINDER



BURR KING MFG. CO., INC.

1220 TAMARA LANE

WARSAW MO 65355

WWW.BURRKING.COM

(660) 438-8998 ♦ (800) 621-2748

FAX (660) 438-8991

June, 2007

Burr King Manufacturing Company, Inc. warrants the below product to be free in material and workmanship. The period of warranty is 1 year (90 days for vibratory bowls of 20 quart and lesser volume) from the date of purchase. No warranty is provided for products that have been modified, abused, handled carelessly, where repairs have been made or attempted by others, or for freight damage. No warranty is provided for three phase electric motors, controllers, etc. when the motors, controllers are not protected by magnetic starters that were supplied and installed by Burr King Manufacturing Company, Inc. No other warranty, written or verbal is authorized by Burr King Manufacturing Company, Inc.

During the warranty period Burr King Manufacturing Company, Inc (or its authorized suppliers or agents) will replace or repair the below product without charge if the product is found by Burr King Manufacturing Company, Inc. to be defective. To receive warranty services you must contact Burr King Manufacturing Company, Inc. and receive authorization fir warranty service. Unless otherwise authorized by Burr King Manufacturing Company, Inc. Products (see * below) must be returned to the factory to receive warranty service.

*Motors, speed controllers, and certain other accessories are warranted by their respective manufactures. To receive warranty service on these items you must contact a brand label service center that supports the product in need of service. Burr King Manufacturing Company; Inc. will assist you in locating a service center.

For the first thirty days after purchase, and when Burr King Manufacturing Company, Inc. authorizes warranty service, we will pay normal and necessary surface freight charges both ways (except for items in *). After thirty days the customer is responsible for all freight charges. Where possible Burr King Manufacturing Company, Inc. may elect to make on site service and/or repairs necessary to return the product to serviceable condition.

To assure prompt warranty service it is necessary that you complete and return the below warranty information to Burr King Manufacturing Company, Inc. please **FAX** or **MAIL** at your convenience.

Product model: _____ Serial number: _____
Date Purchased: _____ Purchased from: _____
Address: _____ City: _____ State/Prov: _____ Postal code _____

Your company name: _____
Address: _____ City: _____ State/Prov: _____ Postal code _____
Phone: _____ Fax: _____ Email: _____
Your name: _____ Title: _____

How did you learn about Burr King products?

Trade show ___ Web ___ Industrial Distributor ___ Advertisement ___ Other _____ Which one: _____

What is the intended use of this product? _____

Please indicate the general work types performed at your company. check all that apply:

Fabrication ___ Machining ___ Casting ___ Molding ___ Welding ___ Finishing ___ Assembly ___ Research ___ Other ___

Please indicate the primary product focus of your company; check all that apply.

Aircraft/Missile ___ Automotive ___ Contract machine ___ Contract Fabrication ___ Agricultural ___ Maintenance ___ Recreational ___

Job shop ___ Foundry ___ Construction ___ Arts ___ Orthopedic ___ Dental ___ Medical ___ Other _____

Please tell us what we can do to improve our products:

May we contact you? Yes ___ No ___

Thank you for purchasing Burr King products!

**REGISTER ONLINE @
WWW.BURRKING.COM**



BURR KING MFG. CO., INC.

1220 TAMARA LANE

WARSAW MO 65355

WWW.BURRKING.COM

(660) 438-8998 • (800) 621-2748

FAX (660) 438-8991

August 29, 2007

LETTER OF AUTHENTICITY

This letter is to certify that all Burr King Belt grinders, Disc grinders, Polishing machines Vibra King Chambers and Bowls are manufactured and assembled in the United States of America.

(Tariff number 847990 criterion A)

A handwritten signature in black ink that reads "Don Mac Carthy". The signature is written in a cursive style with a large, stylized initial "D".

Don Mac Carthy
President

See our catalog at www.burrking.com

contact us at info@burrking.com



BURR KING MFG. CO., INC.

1220 TAMARA LANE

WARSAW MO 65355

WWW.BURRKING.COM

(660) 438-8998 ♦ (800) 621-2748

FAX (660) 438-8991

February 2005

OPERATOR, and OPERATING AREA SAFETY

Subject equipment includes Grinders, buffers, polishers, and other rotating equipment. Serious injury or death may occur if minimum safety precautions are not understood, and obeyed by operators and those other persons who may be in the immediate vicinity of the subject equipment. Persons who operate, or are in the immediate vicinity of the subject equipment must be properly trained in, and use, minimum safety precautions and procedures for such machinery.

Minimum safety requirements to operate, or work in the immediate vicinity subject equipment:

1. Read and understand all operating instructions, manuals, labels, and other information provided with the equipment.
2. Install the equipment according to manufacturer's instructions.
3. Securely bolt the equipment to a rigid, structurally sound mounting surface.
4. Use and wear proper eye and face protection.
5. Use and wear proper protection for the body, hands, fingers, feet, and legs.
6. Review and understand all machine guards, adjustments, and points of exposure to potential injury.
7. Do not remove, tamper with, or otherwise alter, equipment guards, and other safety features.
8. Insure the machine is adjusted, and remains adjusted according to manufacture's requirements.
9. Maintain the equipment in good operating condition.
10. Have another person who is knowledgeable in proper and safe operation of the subject equipment demonstrate proper and safe operation to all operators, and to those persons who might be in the immediate vicinity of the subject equipment.
11. Use work piece holding devices when ever possible that diminish the possibility that persons will come in contact with moving machine pieces, or spark/debris output from the machine.
12. Use spark and debris arresting apparatus. Such apparatus should be connected to the machine so as to contain dust and debris that is generated, and to suppress sparks thereby limiting human inhalation risk, and the risk of fire or explosion.
13. Use appropriate inhalation apparatus to protect person from ingestion and/or inhalation of sparks, debris, smoke, particulates, etc.
14. Avoid mixing different metals, alloys, and materials. To mix such materials might create a fire or explosion hazard.
15. Protect persons from work pieces, particulates, etc. that could be forcibly ejected from the machine. For example, a buffing wheel or grinding belt can "grab" a work piece while the work piece is being buffed, polished, ground, or otherwise conditioned, resulting in forcible ejection toward the operator or those in the vicinity of the machine. The use of leather aprons, gloves, and eye shields are examples of protective gear that may be effective. In general do not grind, buff, or otherwise engage the traveling belt, wheel, or disc surface with the work piece pointing into the direction from which the belt, wheel, or disc is traveling. However, if you choose to do so be aware the work piece may lodge in the traveling belt, wheel, or disc and be forcibly, and dangerously ejected.
16. Do not operate this machine if the gap (nip point) between a moving belt, wheel or disc and the work support surface exceeds 1/8 inch.
17. Do not operate this machine if the gap between the moving abrasive belt, disc or wheel and the adjacent face

page 1 continued on next page

See our catalog at www.burrking.com

Contact us at info@burrking.com

Continued from page 1

of the work rest (or table) will permit passage of the work piece through the gap (nip point). Note, however, that certain alloys such as titanium may create conditions where grinding debris can accumulate in a tight gap creating a potential fire hazard. **When in doubt consult with your safety officer.** Failure to observe this warning may result in the work piece or other item being caught in this gap, and/or being forcibly ejected. Failure to heed this warning may cause serious bodily harm to the operator and/or bystanders. **NEVER USE THIS EQUIPMENT IF YOU ARE NOT PROPERLY TRAINED IN ITS OPERATION and/or SAFE USE! IF IN DOUBT STOP and ASK FOR GUIDANCE!**

18. Never position the work rest table at an acute angle between the top of the work rest table and the moving belt or wheel. Doing so will create “nip point” that can cause serious injury should an operator body part become entangled (pulled into) the nip point created by this acute angle.

19. Do not operate the equipment, or allow others to operate the equipment without proper training in these and other rotating machinery safety requirements.

20. Do not perform maintenance on the equipment unless you are fully qualified to do so, and understand all necessary safety and operating requirements.

21. Do not leave the machine unattended while it is running.

22. Correct equipment or safety problems immediately. Do not operate the equipment when it requires maintenance, or correction.

23. Install and use high quality abrasive belts, wheels, discs, media, etc., as appropriate to your machine. Understand and follow the operating requirements provided by the manufacturer of these materials.

Rotational Speed Warning, Contact Wheels

Scope: Contact wheels manufactured by Burr King Manufacturing Company, Inc., which have rubber or urethane tires. Examples include but are not limited to stock codes 202, 302, 402, 502, 702, 802, 902, 1002, 1202 and variants. Variants have stock codes that begin with the base number; i.e. 802-S-55 is an 802 variant.

Users are warned not to exceed the below listed revolutions per minute (RPM) on the subject wheels. Failure to heed this warning may lead to tire de-bonding, fragmentation, or other mechanical failure. Such failures may cause serious personal injury to operators or bystanders, and/or cause property damage. All Burr King products are warranted for various time periods to be free of material and/or workmanship defects. Burr King Manufacturing Companies standard warranty policy is summarized as follows for contact wheels. 1 year from date of purchase if mounted on a Burr King machine purchased on the same date or 90 days if purchased as a spare or replacement part. Our warranty does not apply to wheels that are mounted on products not manufactured by Burr King Manufacturing Company, Inc. Users who mount Burr King manufactured contact wheels on product not manufactured by Burr King Manufacturing Company, Inc. do so at their own risk and assume all liability for having so mounted the contact wheel(s).

Remember good safety practice demands guarding to protect operators and bystanders from wheel failure and/or debris. Never use the subject contact wheels without proper guarding that meets commonly accepted safe practice. See OSHA, U/L, CSA, CE, ISO and other respected safety standards.

<u>Stock code</u>	<u>Maximum Safe RPM</u>
202, 302	10000
402, 502, 702 802	4400
902, 1002	2200
1202	1600

Page 2, continued on page 3

Continued from page 2

Occupational Noise Exposure

Burr King products produce levels of noise consistent with their intended purposes. The level and spectral content of noise produced is dependent on the product type, the degree that the product is maintained in proper operating condition, the abrasive/media and accessories used, the specific application, and the surrounding environment. Noise levels produced by various Burr King grinders and polishers, as measured at the Burr King factory, range from 80 to 93 decibels. Product operators and persons in the immediate product vicinity should be protected from excessive noise does levels as prescribed in OSHA regulation 29, piece 1910.95 titled "Occupational Noise Exposure".

ROTATING EQUIPMENT CAN BE DANGEROUS TO OPERATORS AND THOSE WHO MAY BE IN ITS IMMEDIATE OPERATING VICINITY. IT IS THE ABSOLUTE AND DIRECT RESPONSIBILITY OF PURCHASERS, MANAGERS, AND OPERATORS OF THIS EQUIPMENT TO UNDERSTAND AND OBEY THE FOREGOING MINIMUM OPERATING SAFETY REQUIREMENTS. IF YOU HAVE QUESTIONS OR SAFETY CONCERNS REGARDING OPERATING THE SUBJECT EQUIPMENT PLEASE CALL YOUR AUTHORIZED BURR KING DISTRIBUTOR, OR BURR KING MANUFACTURING AT 1-800-621-2748. YOUR SAFETY IS OUR FOREMOST CONCERN!

Burr King Manufacturing disclaims any and all responsibility for injuries, damage, loss of income, or other adverse consequence as might be incurred by purchasers, managers, and operators of this equipment.

Page 3 is last page



BURR KING MFG. CO., INC.

1220 TAMARA LANE

WARSAW, MO 65355

WWW.BURRKING.COM

(660) 438-8998 S (800) 621-2748

FAX (660) 438-8991

Technical tip

May 16, 2006

As you may know we improved many of our 120 and 220-volt single-phase variable speed grinders and buffers to use a three-phase AC motor with an inverter controller rather than the DC motors and a rectifier controller previously used. This change is transparent to the end user since the machine is “plugged in” to single-phase outlets. The use of a three-phase motor permits the use of computerized “inverter” controls to achieve variable speed control. Current technology does not support the use of single-phase motors for variable speed operation except through the use of mechanical systems. We made this change for the following reasons:

- Customers frequently demand excess horsepower output from the machines. Regardless of the “labeled” horsepower electric motors can deliver power well in excess to stated capability for short periods of time. Since there is “no free lunch” this excess horsepower is sustained by high current drain on the supply service (what comes out of the wall). Further this high current drain taxes the control module on the grinder or buffer and all interconnect circuitry such as the electrical cord which can get warm as evidence of the overstress. **The new configurations are more tolerant of excess horsepower demand.**
- The DC motors and controllers previously used had fuses that would “blow” when the customer demanded even short periods of overload necessitating the customer searching for and replacing up to two fuses at the machine and perhaps having to reset a wall circuit breaker. **The new configurations are more tolerant of overload, but in the event of an overload the customer needs only to reset the controller.**
- The DC motors require the use of “brushes” that have a specified service life of about 1200 hours with normal loading. Excess loading greatly reduces this time. **The three-phase motors used with the new configurations do not have brushes and are inherently more reliable.**
- The DC controllers previously used are very limited in their ability to be interfaced with external controls as might be found with robotics or other automation devices. **The new AC controllers have greatly expanded interface capability.**
- The DC motors and controls were often limited in their ability to drive the machines to maximum specified belt or wheel speed. **The new configurations can be readily set for optimum advertised speeds.**
- The cost of modern inverter controls is now competitive with the cost of the older DC control modules; and three-phase motors are very competitive with DC motors. **This allows us to deliver a superior value to our customers and to expand the application utility of our products without negatively impacting the price that our customers pay.**

Because of the common and widely used 120 volt single-phase service (your home, office, and in factories) there are some important application aspects that you and our customers need to bear in mind. These apply to the new variable speed configurations or for that matter any electrical motor driven machine where the horsepower is 1-½ or greater. People often do not understand the electrical supply beyond “it comes out of the wall” and “if it is my garage it must work on everything specified 120 volts, single phase”. Many homes, offices, and even factories (in accordance with local and national codes) are wired with 14-gauge feeder wire to the 120-volt outlets making the supplied service inadequate for machines with 1-½ horsepower

motors. To force these inadequate services to deliver power that is greater than their designed 15-ampere capability leads to early equipment failure and potential fire danger. **This must always be considered when choosing the electrical supply.**

- **Burr King provides 1-½ horsepower, 120-volt machines with a 20-ampere power cables and connectors.** This is necessary to assure that the power cord does not dissipate excess energy (delivers all available current to the motor), and to assure that the user plugs into a supply capable of delivering the required 20 amperes of current. You can identify the 20-ampere cable by its 20-ampere plug that has a 90-degree orientation of the two flat blades. **If a user defeats this performance and safety feature he does so at his own hazard.**
- At the application site you and our customer must assure 20-ampere service is used. Should the user defeat the 20 ampere polarized plug provided by Burr King in favor of a 15-ampere service he may experience nuisance circuit breaker trips.
- **A 120 -volt, single phase 1-½ horsepower machine must always be connected to at least a 20-ampere 120-volt source that incorporates 12-gauge wire at minimum. 20-ampere circuit breakers must never be used with smaller than 12-gauge wire. Failure to observe this warning may create a fire hazard and result in the loss of life and or property.**
- It is common (by code and fact) to have five or more AC outlets wired to a single 20-ampere circuit box breaker. This means that when a 20-ampere demanding device (1-½ horsepower motor) is connected to one of the outlets no other device should be connected to the other shared outlets, in other words all of the available current must be reserved for the 1-½ horsepower motor.
- **220-volt, single-phase 1-½ horsepower configurations should be connected to 15-ampere service. Burr King machines are provided with appropriate power cables and connectors for this service arrangement. Similar concerns exist for 220-volt, single-phase systems; however, 120-volt systems are far and away of more concern and therefore require greater awareness and pro action.**
- For 1-½ horsepower, 120-volt, single phase motor applications the use of extension cords should be avoided. If it is necessary for an extension cord to be used assure that the cord does not exceed twenty feet in length and is constructed with 12-gauge or larger wire. **Failure to observe this will lead to reduced performance, premature failure, and a potential fire hazard.**

Remember that this is an important issue that effects product performance, reliability, and physical safety. If you have doubts or need assistance call the factory. The new configuration machines will safely deliver solid performance for many years provided they are supplied with and adequate AC power.

Finally, we think that you will agree the new configuration variable speed machines are a superior value because of their improved reliability, improved tolerance to overloads, and extended capability!



BURR KING MFG. CO., INC.

1220 TAMARA LANE

WARSAW MO 65355

WWW.BURRKING.COM

(660) 438-8998 ♦ (800) 621-2748

FAX (660) 438-8991

August 2002 Rev A

Operating instructions for the Model 960-401 wet belt grinder

The model 960-401 belt grinder is a two-wheel path belt grinder that uses a 2.5 or 4.0 x 60-inch continuous loop abrasive belt. The grinder is intended for wet abrasive belt operation such as may be required for glass finishing or lapidary work. For maximum effectiveness, and operator safety uses abrasive belts manufactured by well-respected abrasive manufacturers.

- Use abrasive belts that are the proper size and type for your machine.
- Do not use abrasive belts that are old and excessively worn.
- Do not use abrasive belts that use lap splice joints. This type of belt is prone to separate. It also may tend to snag your work and create a safety hazard. It may also perform poorly.
- Do not use metalized belts or other belts with sharp edges. Belts of these configurations could present serious cutting injury potential to the operator or to bystanders should the belt inadvertently leave the machine while the machine is in motion.
- Never touch or otherwise contact any portion of the abrasive belt while it is in motion. Doing so could result in serious personal injury.

Prior to operating the model 960-401 please take time to do the following:

1. Insure that you have received all of the items that you ordered. Compare the packing slip with your purchase order, and of course with the physical items received.
2. Verify that there is no obvious shipping damage. If shipping damage is discovered notify the freight carrier of your intention to file a freight damage claim. They will assist you.
3. Verify that the AC power that is identified on the machine as received matches the AC power that you intend to operate the machine with. Do not modify the machines wiring without first contacting your distributor or Burr King manufacturing.
4. Do not modify or defeat any AC wiring safety feature. In example, do not remove the grounding pin on the AC plug, or defeat the ground fault interrupt system if so equipped.
5. Verify that you have received a warranty card, parts lists, catalog, and **Operator, and Operating Area Safety Instructions.**
6. Complete the warranty card and return it to Burr King Manufacturing.
7. Verify that the various guards for the machine are in place and functional. See the parts list for the indicated part numbers.
 - a. The contact wheel guard (903-4) is a mounted and adjusted such that pinch guard plate (914) if used, is about 1/8 inch behind the abrasive belt and the contact wheel guard covers side of the contact wheel (802-4) away from the operator. Where the pinch guard (914) is not mounted back-up platen assembly (904-4) must be mounted to protect the pinch point that exists at the junction of the moving belt and the contact wheel (804-4, i.e.). Burr King Manufacturing Company supplies one or both of these assemblies with each machine shipped. **FOR YOUR SAFETY DO NOT OPERATE THE 960-401 WITH THE PINCH GUARD, BACK UP PLATEM ASSEMBLY OR ANY OTHER GUARD REMOVED OR NOT PROPERLY ADJUSTED.**
 - b. The full safety guard is in place, closed and its door latch is functional such that it will securely hold the safety door closed (P/N 942A-1. 942-4B)
8. Prior to operating the model 960-401 read the **Operator and Operating Area Safety Instructions** carefully. Insure that all persons who will operate the model 960-401, or who will work in the vicinity of the model 960-401 read, understand, and comply with these instructions.

9. Insure that the grinder is located in a work area that provides clear access to the machine such that operators have clear and unobstructed access to the machine. The work place should be free from floor obstructions, trip points, and other faults that may reduce operator safety.
10. Burr King recommends that all three-phase installations include a magnetic starter. Magnetic starters protect motors from “single phasing”, overheating, etc. thereby reducing the risk of damage to the equipment and/or fire hazard to your facility.
11. Insure that the model 960-401 AC power source is properly sized, and properly fused. You should consult a competent electrician, or you may call Burr King Manufacturing for guidance.

Functional operating instructions for the model 960-401 belt grinder

The model 960-401 was fully tested and verified to comply with requirements prior to shipping from the factory. You should perform the following steps in preparation for using the grinder:

1. With the machine securely bolted to its table, pedestal, and/or floor point connect the AC power to its source.
2. Insure that the abrasive belt is tensioned properly. To do this, raise the tensioning handle (P/N 937G). You will hear mechanical clicks as the tensioning ratchet pawl (737F) moves. Generally, the belt will be adequately tensioned when you hear three to eight clicks. To reduce or release the belt tension slightly raise the tensioning handle (P/N 737A) then press the button (P/N 737B) in the center of the tensioning handle. Move the tensioning handle down slightly to reduce belt tension or all the way down to release belt tension.
4. Engage the motor by placing the ON/OFF switch to ON. The belt should rotate smoothly in a CCW direction about the machine wheel belt path as you face the right side of the machine. If either of these conditions is a not met turn the machine OFF immediately.
 - a. If the abrasive belt does not remain centered on the contact wheel (802-4) while the belt is moving use the tracking adjustment (P/N 921-4) on the upper left side of the machine to track the belt. Turning this control CW to causes the belt to track to the right, conversely turn the control CCW to causes the belt to move to the left.
 - b. If the belt runs in reverse (up from the floor) you must correct this by changing the main drive motor rotation direction. **A COMPETENT ELECTRICIAN SHOULD PERFORM ALL ELECTRICAL WORK ON THE MODEL 960-401.**
 - 1) Reversed the motor direction of a three-phase motor by reversing any two legs of the input power lines.
 - 2) Reverse the motor direction of a single phase motor by reversing leads 5 and 8 found within the metal wiring box located on the motor, or as otherwise instructed on the actual motor label.
 - c. If the machine belt tensions, and tracks properly, but has excessive vibration turn the machine OFF and call the Burr King factory for assistance.

Belt speed

The 960-401 will operate at two different belt speeds (fixed speed model). It is shipped from the factory in the high-speed mode of approximately 4700 surface feet per minute (SFPM). To change to the lower belt speed of approximately 2100 SFPM it is necessary to reverse the drive pulleys. To do this first remove electrical power ten:

- remove the rear idler wheel
- remove the pinch guard
- remove the main belt guard
- locate the hex head bolts that secure the two halves of the main frame together, support the frame and remove these bolts.
- loose the two elastic hex bolts that secure the motor side of the frame to the motor, do not remove these.
- remove the v-belt
- remove and reverse the v-pulleys taking care to align them so that the v-belt tracks true and the pulleys do not drag the frame.
- reassemble
- tighten the v-belt and secure by tightening the elastic nuts.

- check for proper operation

Using the water system that is part of the 960-401 grinder.

The 960-401 is equipped with a re-circulating water fed system that is intended to bath the abrasive belt, gather in the water, and return the water and grinding slurry into a pail.. The system consists of:

- one 5 gallon pail
- one low pressure pump
- one stainless steel pump bracket
- one metering valve
- two spray nozzles
- one stainless steel fluid gathering tray
- necessary tubing, connections, etc. to permit fed and drain of the water and slurry.

The water system is intended ONLY for water. Do not substitute other solvents they may create a fire, electrocution, or chemical hazard to operator and/or the equipment.

Operation of the water fed system is simple.

- Adjust the water flow to the desired volume by using the valve located on the rear of the machine guard.
- The water spray is factory adjusted to address the abrasive belt when the machine is operated in any attitude from a horizontal to a vertical belt track position.
- The water is returned into the pail via the gathering tray and its associated drain hose that extends to the water pail.
- The water deliver system and the recovery drain apparatus is designed to work in any machine position from a horizontal to a vertical belt angle.

NEMA 4 electrical system

The 960-401 wet grinder is factory equipped with a motor, switch, and cord that are NEMA 4 rated for wet operation. This means that they may be used in wet locations, but not in locations where flooding of the equipment is probable. The 960-401 also is equipped with a ground fault interrupt plug, and a central ON/OFF switch mounted in a “rain” type electrical box intended for mounting away from the wet abrasive belt location. **AVOID ELECTICUTION, DO NOT MODIFY OR DEFEAT THE NEMA 4 ELECTRICAL SYSTEM.** If your 960-401 requires electrical work insure that a qualified electrician who understands NEMA 4 requirements performs the work.

In the event the GFI circuit breaker open circuits you must investigate for and correct the problem. **Failure to correct an electrical ground fault condition may result in electrocution**

Maintenance for the model 960-401

FIRST DISCONNECT THE MACHINE FROM ITS AC POWER SOURCE.

- * Every thirty days check the v-belt (P/N 429) tension. If you can hear the belt “slap” the v-belt guard (P/N 928-4) when the drive motor starts, the v-belt may require re-tensioning. Do this by loosening the two nuts (P/N 39) that secure the motor to the v-belt guard (P/N 928-4) and slide the guard forward. Tighten the two nuts (P/N 39).
- * Daily vacuum or otherwise remove dust and debris build-up from the machine and the machine belt track.
- * Routinely inspect for loose screws and other hardware and tighten as required.
- * If the rear wheel assembly (945) does not operate smoothly it may require lubrication. To re-lubricate you must disassemble the 945, clean it with a mild solvent, and greaser it lightly with a good grade of marine bearing grease such as NLGI type GC-LB intended for water bathed applications. Do not use ordinary bearing grease as the water used in your glass(i.e.) grinding process will dilute the grease making it ineffective.

There are a no other maintenance actions required. All bearings is a sealed for life and require no additional lubrication.

Remember for operator safety and the continued effectiveness of your model 960-401:

Do not defeat the safety guards and other safety provisions of the model 960-401.

Do not operate the model 960-401 with the safety guard open or the contact wheel guard/platen assembly (or internal grinding attachment) removed.

Do not reach inside the safety guards while the machine is running. To do so is hazardous.

Do not use fluids in your grinding process unless your model 960-401 is designed for liquid operation (NEMA 4, 4X). To do so may create an electrical safety hazard.

Do not use your model 960-401 to grind/polish explosive materials such unless it is equipped with explosion proof electrical devices and motor.

Do not mix alloys in your grinding. To do so may create an explosion hazard.

Do not use stone or vitreous wheels on the model 960-401. To do so will create an operator safety hazard.

Do use eye, hand, face, arm, leg, feet and body protection that is adequate to protect against flying debris, forcibly ejected work pieces, broken abrasive belts, etc.

Do train operators and others in safe operating practices.

Post these or equivalent instructions such they are available for ready operator reference.

Burr King Manufacturing can help you with problem solutions, and/or answers to your questions. Please call your Burr King distributor first. If you can not reach satisfactory conclusion please call the Burr King factory, telephone 1-660-438-8998.

M960-401

SCHEMATIC

945S

BURR KING

1220 TAMARA LANE
WARSAW, MO. 65355

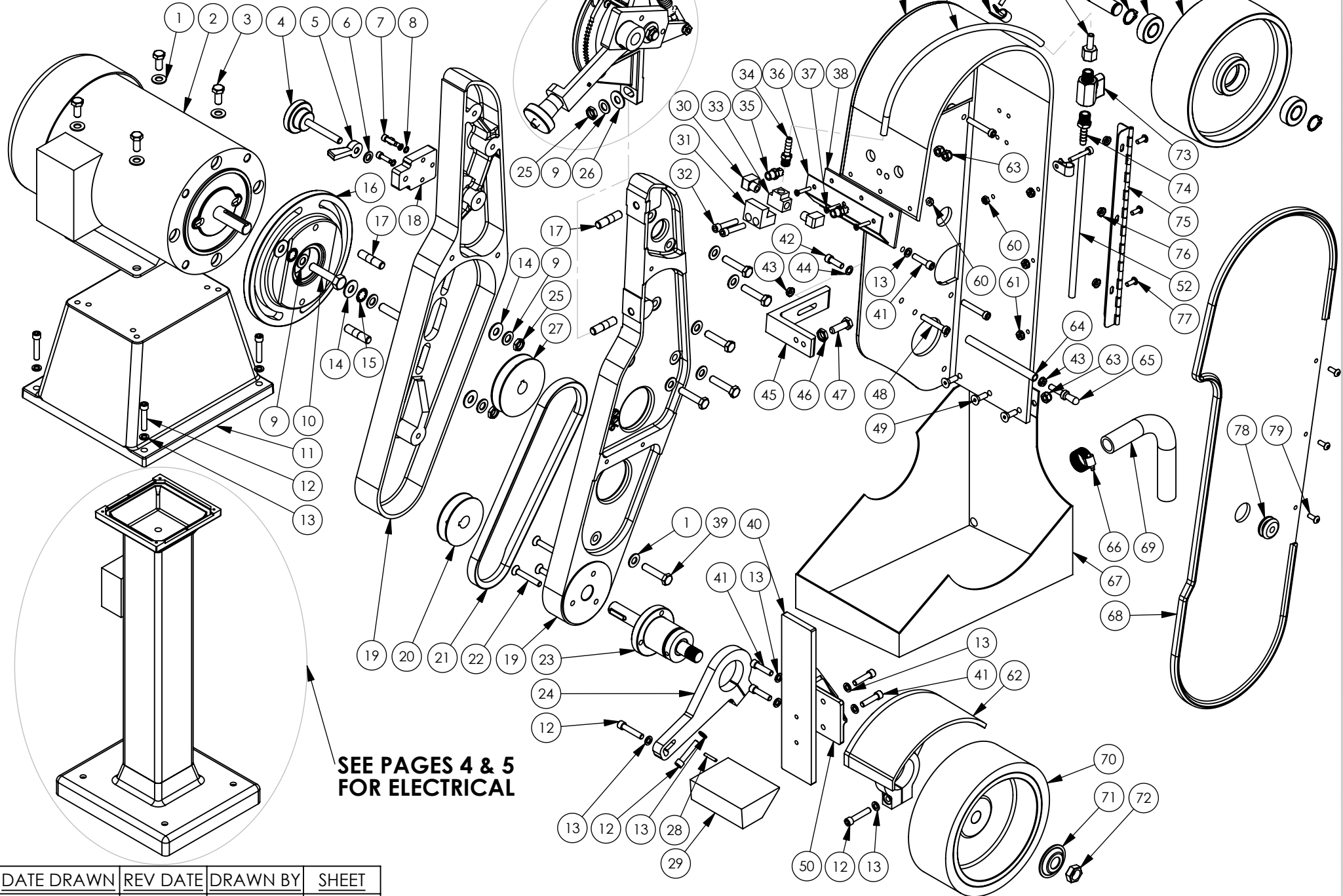

**SEE PAGES 4 & 5
FOR ELECTRICAL**

DATE DRAWN	REV DATE	DRAWN BY	SHEET
9/25/2009		CMW	1 OF 6

945-4S

BURR KING

1220 TAMARA LANE
WARSAW, MO. 65355

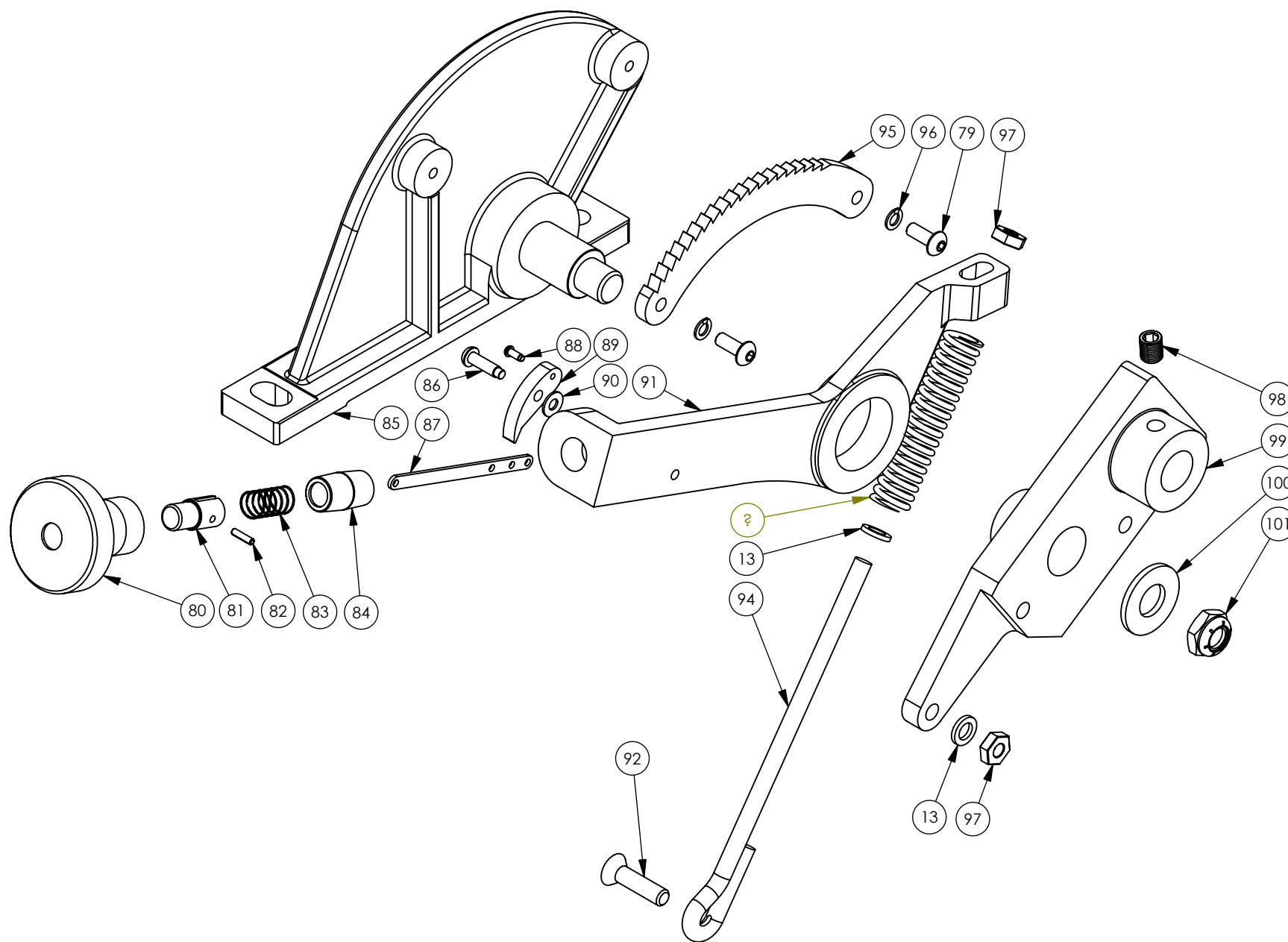

TITLE	DATE DRAWN	REV DATE	DRAWN BY	SHEET
M960-401	9/25/2009		CMW	2 OF 6

M960-401			
ITEM NO.	PART NUMBER	DESCRIPTION	QTY.
1	4	WASHER, 5/16 SAE ZINC PLTD	10
2	MOTOR	CALL FACTORY	1
3	37	BOLT, 5/16-18x3/4 HH, GRD5, PLTD	4
4	921-4	KNOB, TRACKING ASSY	1
5	922	LOCK, KNOB, TRACKING	1
6	18	WASHER, 960-516, AN	1
7	2-0023	SCREW, 10-24 X 5/8 SC ALLEN	3
8	5-0035	WASHER, #10, LOCK, HIGH COLLAR	3
9	17	WASHER, 960-616, AN	6
10	1-0003	BOLT, 3/8-16 x 1 1/4 HEX HEAD	2
11	941	BASE	1
12	31	SCREW, 1/4-20x1 1/4 SOC CAP	7
13	5	WASHER, 960-416, AN	12
14	42	WASHER, 3/8,THRU-HARD, YZ	4
15	5-0014	WASHER, 3/8, LOCK, INTERNAL STAR	2
16	908	ADAPTER, C-FACE MOTOR	1
17	920	STUD 3/8"x1 1/2", DOUBLE	4
18	923-4	BRACKET, TRACKING	1
19	900-4	FRAME/GUARD, ASSEMBLY	1
20	725	PULLEY, 2 1/2"	1
21	429K	BELT, V, NOTCHED, 4L240	1
22	6	SCREW, 1/4-20 x 1 1/2 FH ALLEN	3
23	701	BEARING, CONTACT WHEEL ASSY	1
24	705-1	ARM, WORKREST SUPPORT	1
25	39	NUT, 3/8-24, JAM, ESNA, NTE	4
26	40	WASHER, 3/8, SAE, PLTD	1
27	730	PULLEY, 3"	1
28	6-0014	PIN, 1/8 X 3/4, ROLL	1
29	706-1	WORKREST, ANTI-TILT	1
30	3569	ELBOW, STREET, EXTRUD, 1/8NP	2
31	3571	BLOCK, SECURING	1
32	1-0035	BOLT, 1/4-20 x 1.25, SOC CAP SS	2
33	3570	TEE, BRASS, EXTRUDE, 1/8NPTF	1
34	3572	BARB, 1/8MP TO 1/4 TUBE, BRASS	1
35	3568	NOZZLE, SPRAY, BRASS, V8NPT	2
36	3577-3	BRACKET, BRUSH RETAINING	1
37	3-0026	SCREW, 8-32 x 1, FLATHEAD, PHILLIPS, SS	3
38	3577	FELT	1
39	1-0019	BOLT, 5/16-18x1 1/2 HH, CS, ZN PLTD	6
40	904A	PLATEN, BACKUP	1
41	30	SCREW, 1/4-20x1 SHCS	5
42	209	SCREW, 1/4-20 X 3/4 SHCS	1
43	4-0013	NUT, 1/4-20, KEP	2
44	5-0032	WASHER, 1/4, LOCK, SPLIT, PLTD	1
45	924	SUPPORT, BACKUP	1
46	4-0009	NUT, 5/16-18, JAM, PLTD	1
47	1	BOLT, 5/16-18x1, HH, GRD 5, PLTD	1
48	2-0011	SCREW, 1/4-20 X 1.5 SOC CAP	3
49	3-0039	SCREW, 1/4-20 x 3/4, S/S FH SCS	3
50	904B	BRACKET, PLATEN	1
51	942-4S	GUARD, SAFETY, PAINTED	1
52	3408	TUBING, CLEAR, FLEXIBLE, 1/4ID	1
53	3578	CLAMP,3/8OD, PLS. HOSE	2
54	3-0036	SCREW, 10-32 X 1 1/4 ALLEN CAP	2
55	3340	BARB, HOSE, FM, 1/4H x 1/4F	1
56	707c	SHAFT, BEARING	1
57	701F	RING, RETAINING, 5/8 EXTERNAL	2

M960-401			
ITEM NO.	PART NUMBER	DESCRIPTION	QTY.
58	701B	BEARING	2
59	907	WHEEL, IDLER	1
60	4-0025	NUT, 8-32, ELASTIC, STOP, SS	5
61	23	NUT, 6-32, KEP, PLTD	3
62	903	GUARD, CONTACT WHEEL	1
63	4-0022	NUT, 1/2-20, NYLOK, SS	5
64	942C-4	STANDOFF, DOOR	1
65	742L1	LATCH, STUD, CLEAR ZN PLTD	1
66	3406	CLAMP, HOSE, 7/16" TO 1"	1
67	DF4-1	SCOOP, FLUID, SS	1
68	942B-1	DOOR, GUARD	1
69	3409	HOSE, STL. REINF., 5/8ID VIN	1
70	802	CONTACT WHEEL, 7x2.5, 55 DURO	1
71	726	FLANGE, OUTER WHEEL	1
72	727	NUT, 5/8-18 RH, JAM, BRT PLT	1
73	3337	VALVE, LOW PRESSURE, 1/4 NPT	1
74	3339	BARB, ML, HOSE, 1/4H x 1/4M	1
75	742E	HINGE, GUARD TO DOOR	1
76	14	NUT, 10-24, KEP	3
77	24	SCREW, 6-32 x 1/2, MACH	3
78	742H	GROMMET, SAFETY GUARD DOOR	1
79	9	SCREW, 10-24x1/2 BH, BLK OXIDE	3

945-4S			
ITEM NO.	PART NUMBER	DESCRIPTION	QTY.
80	737A	KNOB, HANDLE	1
81	737B-1	BUTTON	1
82	26	PIN, 3/32 x 3/8, ROLL PLTD	1
83	737D	SPRING, REAR WHEEL ASSY	1
84	737E	NIPPLE, HANDLE	1
85	940	SUPPORT, IDLER WHEEL	1
86	27	SCREW, #8 X 5/8, DRIVE	1
87	937BA	STRIP, BUTTON ASSEMBLY	1
88	28	SCREW, #2 x 1/4, DRIVE	1
89	737F	PAWL	1
90	5-0027	WASHER, #8,18-8 STAINLESS STEEL	1
91	937G	HANDLE	1
92	34	SCREW, 1/4-20 X 1, FH PHILLIPS	1
93	989	SPRING, BELT TENSION	1
94	939	GUIDE, SPRING	1
95	736	SECTOR	1
96	15	WASHER, #10, LOCK	2
97	3	NUT, 1/4-20 JAM, PLTD	2
98	25	SCREW, 5/16-18 x 3/8, SET, SOC	1
99	935	SUPPORT, REAR WHEEL	1
100	21	WASHER, 1/2 SAE, FLAT, ZINC	1
101	20	NUT, 1/2-20, JAM, ESNA, NTE	1

*** USES A 011D TOGGLE SWITCH**

TITLE	DATE DRAWN	REV DATE	DRAWN BY	SHEET
M960-401	9/25/2009		CMW	3 OF 6

BURR KING

1220 TAMARA LANE
WARSAW, MO. 65355

115 SET UP

BURR KING

1220 TAMARA LANE
WARSAW, MO. 65355

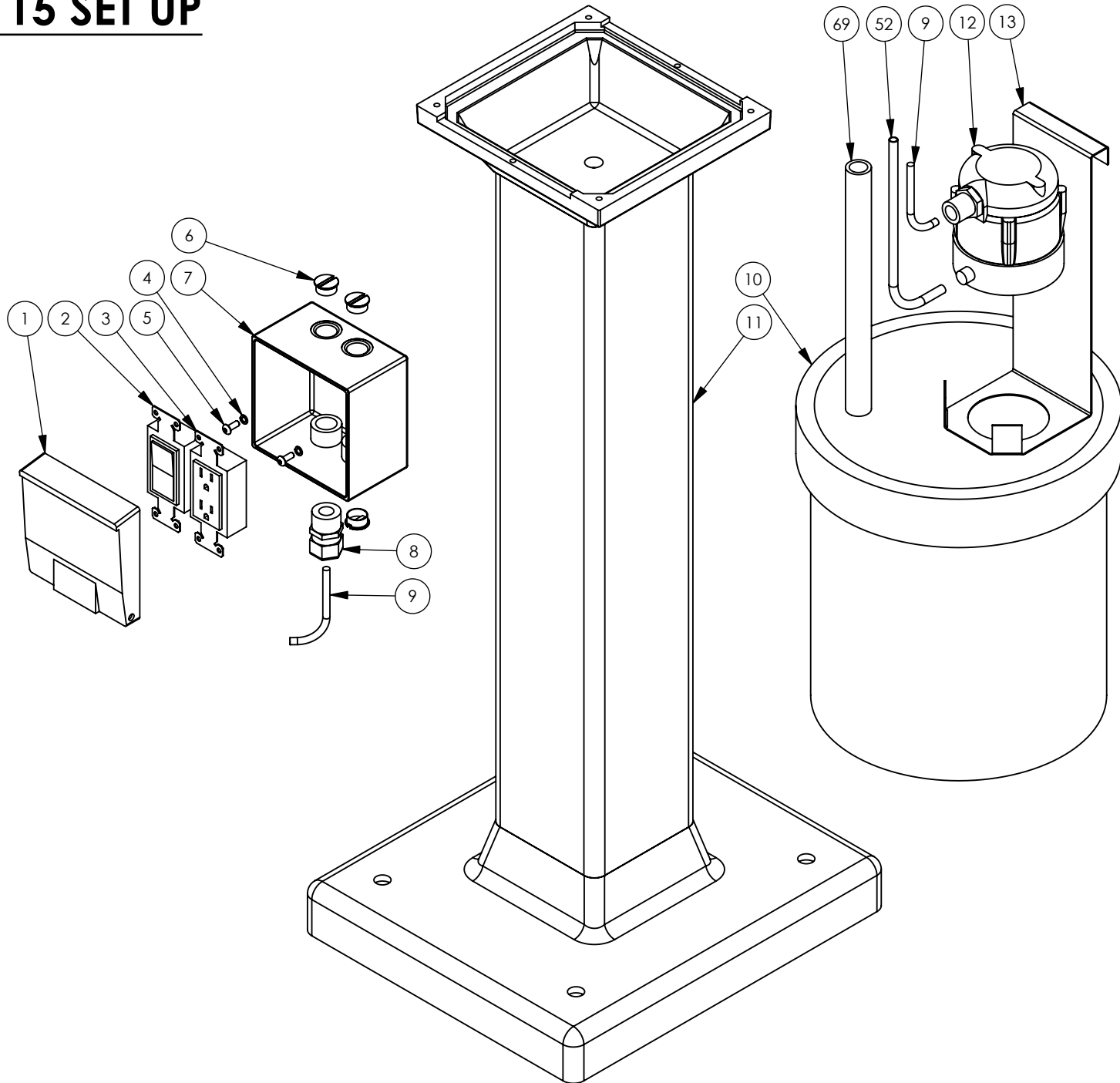

TITLE	DATE DRAWN	REV DATE	DRAWN BY	SHEET
M960-401	9/25/2009		CMW	4 OF 6

220 SET UP

BURR KING

1220 TAMARA LANE
WARSAW, MO. 65355

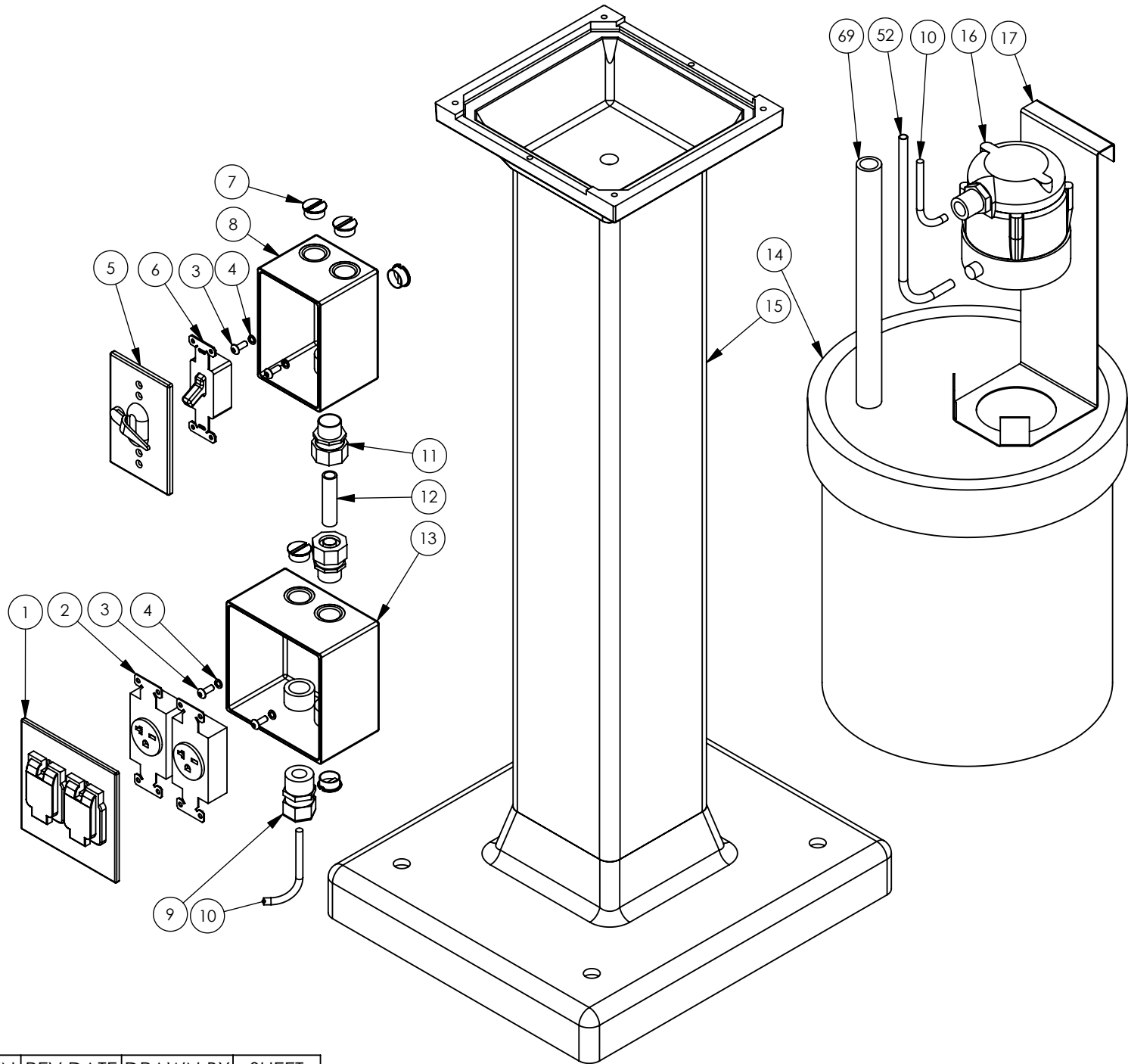

TITLE	DATE DRAWN	REV DATE	DRAWN BY	SHEET
M960-401	9/25/2009		CMW	5 OF 6

115V SET UP

ITEM NO.	PART NUMBER	DESCRIPTION	QTY.
1	9952	COVER, 2 GANG RAYNTITE,5045-0	1
2	9951	SWITCH, ROCKER, 15A, 120V,	1
3	9950	RECEPTACLE, GFI, DUPLEX, 120V	1
4	15	WASHER, 5/16 LOCK, SPLIT	2
5	9	SCREW, 10-24x1/2 BH, BLK OXIDE	2
6	9902	PLUG, 1/2" CONDUIT	3
7	3326	BOX, WP, 2 GANG, DEEP	1
8	3356	RELEIF, STRAIN, 1/2"	1
9	015	CORD	2
10	3317	PAIL, 5 GAL. PLASTIC, BLACK	1
11	02	PEDESTAIL	1
12	3316-3	PUMP, WATER/120V/1PH/60HZ	1
13	3331	BRACKET, PUMP HANGER	1
52	3408	TUBING, CLEAR, FLEXIBLE, 1/4 ID	1
69	3409	HOSE, STL. REINF. 5/8 ID VIN	1

220V SET UP

ITEM NO.	PART NUMBER	DESCRIPTION	QTY.
1	3567-2	COVER, 2 GANG, 2 SGL, RCPT, WP	1
2	3329-1	RECP, 20A SINGLE 250V	2
3	9	SCREW, 10-24x1/2 BH, BLK OXIDE	4
4	15	WASHER, #10 LOCK	4
5	3325	COVER, SINGLE, LEVER, RAIN	1
6	3323	SWITCH, TOGGLE	1
7	9902	PLUG, 1/2" CONDUIT	5
8	3354	BOX, WP, SINGLE, DEEP	1
9	3356	RELEIF, STRAIN, 1/2"	1
10	017	CORD	2
11	775	CONNECTOR, 3/8" STR, LIQ. TIGHT	2
12	020	CONDUIT, 3/8", LIQ. TIGHT	1
13	3326	BOX, WP, 2 GANG, DEEP	1
14	3317	PAIL, 5 GAL. PLASTIC, BLACK	1
15	02	PEDESTAIL	1
16	3316-1	PUMP, WATER, 220V/1PH/50-60HZ	1
17	3331	BRACKET, PUMP HANGER	1
52	3408	TUBING, CLEAR, FLEXIBLE, 1/4 ID	1
69	3409	HOSE, STL. REINF. 5/8 ID VIN	1

TITLE	DATE DRAWN	REV DATE	DRAWN BY	SHEET
M960-401	9/25/2009		CMW	6 OF 6